

Precision slides



5 Positioning systems

Precision slides

Precision slides

RSS

Precision slides with crossed roller units and pre-loaded planetary roller screws

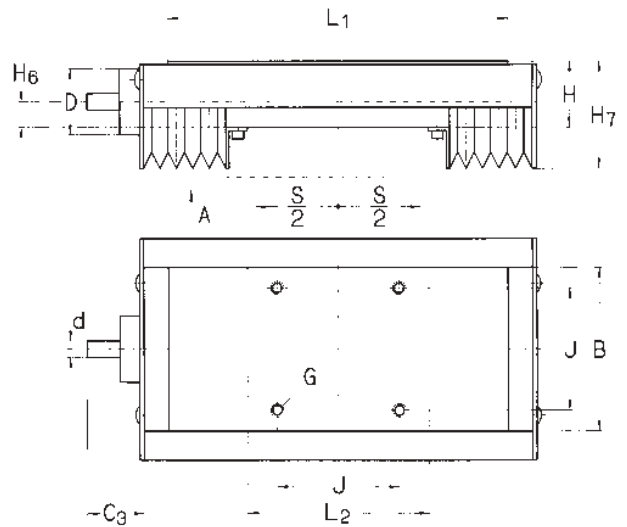
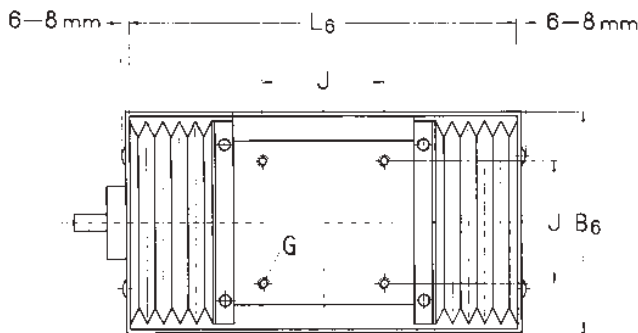

Designations	Dimensions			Stroke Maximum stroke between end stops							Load-carrying capacities					
	B	H	L ₁	L ₂	S	B ₆	C ₃	d	D	H ₆	H ₇	J	L ₆	G	N	C ₀
mm																kN
RSS100.260.050	100	40	260	210	50	164	19	5	30	15.5	65	74	290	M6	6.6	8.8
RSS100.310.050	100	40	310	260	50	164	19	5	30	15.5	65	74	340	M6	6.6	10.9
RSS100.360.050	100	40	360	310	50	164	19	5	30	15.5	65	74	390	M6	6.6	13
RSS100.310.100	100	40	310	210	100	164	19	5	30	15.5	65	74	340	M6	6.6	8.8
RSS100.360.100	100	40	360	260	100	164	19	5	30	15.5	65	74	390	M6	6.6	10.9
RSS100.410.100	100	40	410	310	100	164	19	5	30	15.5	65	74	440	M6	6.6	13
RSS100.360.150	100	40	360	210	150	164	19	5	30	15.5	65	74	390	M6	6.6	8.8
RSS100.410.150	100	40	410	260	150	164	19	5	30	15.5	65	74	440	M6	6.6	10.9
RSS100.460.150	100	40	460	310	150	164	19	5	30	15.5	65	74	490	M6	6.6	13
RSS100.460.200	100	40	460	260	200	164	19	5	30	15.5	65	74	490	M6	6.6	10.9
RSS150.410.100	150	50	410	310	100	214	30	10	47	24	75	116	450	M8	9	35
RSS150.510.100	150	50	510	410	100	214	30	10	47	24	75	116	550	M8	9	48.8
RSS150.610.100	150	50	610	510	100	214	30	10	47	24	75	116	650	M8	9	60.5
RSS150.510.200	150	50	510	310	200	214	30	10	47	24	75	116	550	M8	9	35
RSS150.610.200	150	50	610	410	200	214	30	10	47	24	75	116	650	M8	9	48.8
RSS150.710.200	150	50	710	510	200	214	30	10	47	24	75	116	750	M8	9	60.8
RSS150.610.300	150	50	610	310	300	214	30	10	47	24	75	116	650	M8	9	35
RSS150.710.300	150	50	710	410	300	214	30	10	47	24	75	116	750	M8	9	48.8
RSS150.810.300	150	50	810	510	300	214	30	10	47	24	75	116	850	M8	9	60.8
RSS150.810.400	150	50	810	410	400	214	30	10	47	24	75	116	850	M8	9	48.8

Continued

RSS
(continued)

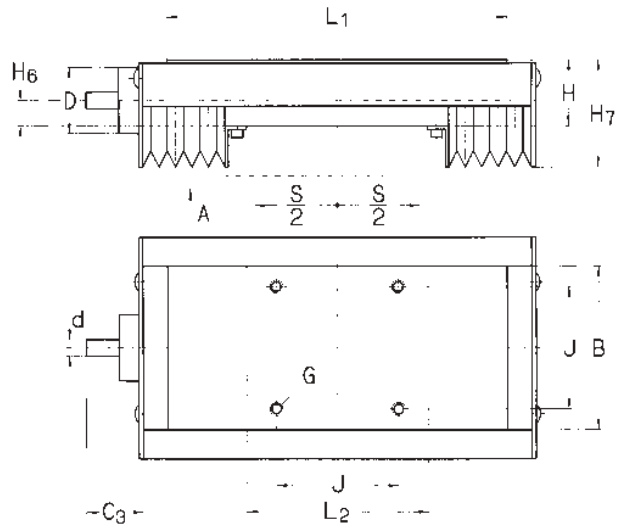
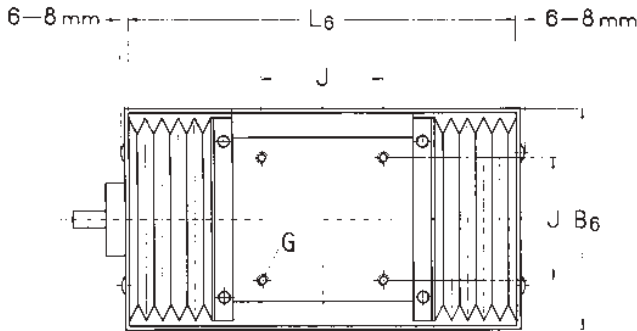

Continued

Designations	Dimensions				Stroke Maximum stroke between end stops							Load-carrying capacities				
	B	H	L ₁	L ₂	S	B ₆	C ₃	d	D	H ₆	H ₇	J	L ₆	G	N	C ₀
mm																kN
RSS200.410.100	200	60	410	310	100	264	30	10	47	25	85	154	450	M8	9	35
RSS200.510.100	200	60	510	410	100	264	30	10	47	25	85	154	550	M8	9	48.8
RSS200.610.100	200	60	610	510	100	264	30	10	47	25	85	154	650	M8	9	60.5
RSS200.510.200	200	60	510	310	200	264	30	10	47	25	85	154	550	M8	9	35
RSS200.610.200	200	60	610	410	200	264	30	10	47	25	85	154	650	M8	9	48.8
RSS200.710.200	200	60	710	510	200	264	30	10	47	25	85	154	750	M8	9	60.5
RSS200.610.300	200	60	610	310	300	264	30	10	47	25	85	154	650	M8	9	35
RSS200.710.300	200	60	710	410	300	264	30	10	47	25	85	154	750	M8	9	48.8
RSS200.810.300	200	60	810	510	300	264	30	10	47	25	85	154	850	M8	9	60.5
RSS200.810.400	200	60	810	410	400	264	30	10	47	25	85	154	850	M8	9	48.8
RSS200.910.400	200	60	910	510	400	264	30	10	47	25	85	154	950	M8	9	60.5
RSS300.515.100	300	75	515	415	100	364	36	10	55	28	100	245	559	M10	11	16.8
RSS300.615.100	300	75	615	515	100	364	36	10	55	28	100	245	659	M10	11	20.6
RSS300.515.200	300	75	515	315	200	364	36	10	55	28	100	245	559	M10	11	12.2
RSS300.615.200	300	75	615	415	200	364	36	10	55	28	100	245	659	M10	11	16.8
RSS300.715.200	300	75	715	515	200	364	36	10	55	28	100	245	759	M10	11	20.6
RSS300.615.300	300	75	615	315	300	364	36	10	55	28	100	245	659	M10	11	12.2
RSS300.715.300	300	75	715	415	300	364	36	10	55	28	100	245	759	M10	11	16.8
RSS300.815.300	300	75	815	515	300	364	36	10	55	28	100	245	859	M10	11	20.6
RSS300.815.400	300	75	815	415	400	364	36	10	55	28	100	245	859	M10	11	16.8
RSS300.915.400	300	75	915	515	400	364	36	10	55	28	100	245	959	M10	11	20.6

5 Positioning systems

Selection of screw for precision tables RSS/Linear ball bearing table with drive

Preloaded planetary roller screws. Accuracy class G₅ ($v_{300p} = 23 \mu\text{m}$)

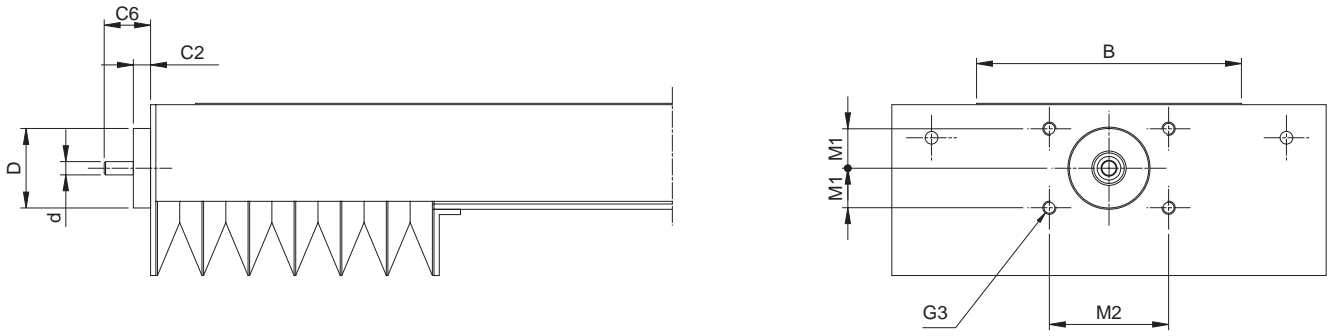

Dimensions	Screw Ø	Lead	Load-carrying capacity ¹⁾		Table driving torque	
			Screw		Idling speed ²⁾	Max. permissible
B	d _o	p	C _a	C _{oa}	M _s	M _a
mm			kN		Nm	
100	R0801	1	3.1	3	0.08	0.4
	R0802	2	3.6	4.3	0.09	1.2
	R0804	4	4.4	4.4	0.11	1.5
	R0805	5	4.4	4.2	0.12	1.5
200	R1202	2	3.7	4.6	0.21	1.2
	R1204	4	4.4	4.5	0.23	2.4
	R1205	5	4.8	4.7	0.24	3.1
300	R1502	2	5.5	7.6	0.29	2
	R1504	4	6.6	7.4	0.31	3.9
	R1505	5	7.2	7.7	0.32	5.1

¹⁾ With compressive load the screw should be checked for buckling
²⁾ M_s = max. required driving torque at the screw for the unloaded table

Screw type	Stroke	Screw length ³⁾	Max. screw speed	Screw abutment dimensions				
				C ₂	C ₆	G ₃	M ₁	M ₂
	mm	S	min ⁻¹	mm				
R08	50	154	12 000					
	100	195	11 000					
	150	245	6 400	6	17	2 × M5	-	45
	200	295	4 200					
R12	100	220	8 500					
	200	320	6 000					
	300	420	3 200	9	28	4 × M6	15	70
R15	400	520	2 000					
	100	225	6 600					
	200	325	7 300					
	300	425	3 900	9	34	4 × M6	15	70
	400	524	2 400					

³⁾ Total length of screw: for calculation of rotary moment of inertia

5 Positioning systems

Slides, tables and compact cross tables

Slides, tables and compact cross tables

Ordering key

	R	SS						
Type:								
Precision slides with rail guide system, needle rollers	N							
Precision slides with rail guide system, dry sliding liners	P							
Precision slides with rail guide system, crossed rollers	R							
Dovetail slides	S							
Compact cross tables with rail guide system, crossed rollers	T							
Versions:								
Only valid for compact cross tables:								
For manual operation, with micrometer knurl		SM						
For motor drive		SS						
Only valid for precision tables:								
For manual operation, with hand crank		SK						
For motor drive		SS						
Only valid for dovetail tables:								
For manual operation, with hand crank		SK						
For manual operation, with micrometer knurl		SM						
Table width B [mm] (see next tables):								
.			85 - 300					
Length L₁ [mm]:								
Dovetail and precision slides							X	
Not applicable to compact cross tables							-	
Nominal stroke [mm]:								
See next tables								
Designation suffix if desired:								
Slides or tables made of aluminium, black anodised								A
Slides with thick top: only for precision slides								D
Slides with thick top and T-slots: dovetail and precision slides								DT
Locking device for dovetail slides (standard)								AR 1
Locking device for precision slides and tables								AR 2
Locking device for compact cross tables (standard)								AR 3
For motor drive only:								
Preloaded planetary roller screw								R
Screw diameter ø in mm:								
Precision tables								8 - 20
Screw lead:								
1 - 5 mm								01 - 05

Example 1: R SS 200 - 710 - 300 - - R 1202

Example 2: R SK 50 - 080 - 025

Example 3: S SM 300 - 010 - 500 - AR1

Example 4: S SK 50 - 080 - 025 - AR1

Example 4: T O 085 - 050 - - AR3