

ACSM precision rail guides with innovative cage guidance system

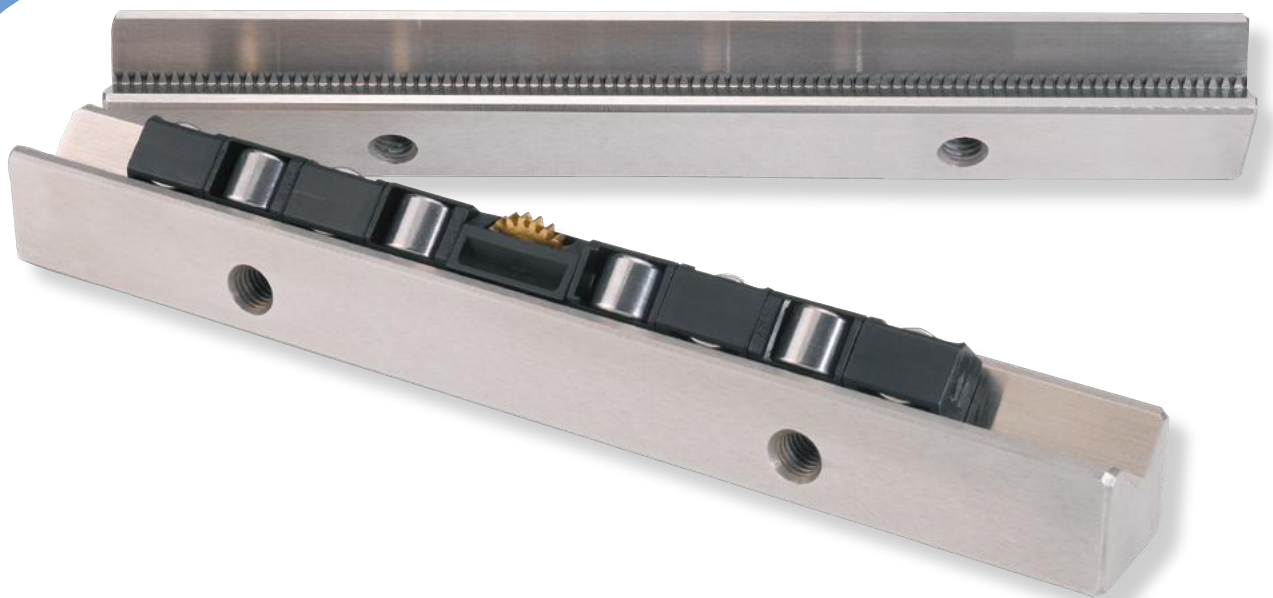

ACSM—Consistent refinement of the SKF patent

Back in 1994, SKF was the first bearing supplier to develop a monolithic ACS cage guidance system (Anti Creeping System), to effectively prevent cage creep. This solution has been copied by numerous competitors ever since. Now SKF has consistently refined its own ACS solution into the Anti Creeping System Module (ACSM).

The new ACSM features

Module gearing with involute gear wheel

Low friction and a high contact ratio are characteristic features of the involute gearing principle. Since SKF attaches the greatest importance to supreme precision, running accuracy and reliability of all its products, this type of gear wheel is used for the ACSM.

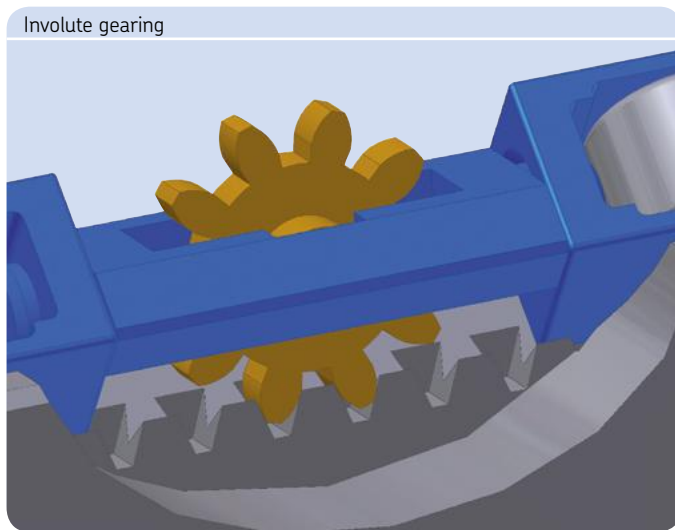

Only the best goes into our standard products: Corrosion-resistant steel

The semiconductor and food industries as well as the chemical and medical engineering sectors are advancing rapidly. This goes hand in hand with ever increasing demands on the materials and equipment used. The ACSM takes this development into account. Its rails and rolling elements are manufactured from corrosion-resistant steel. In response to frequent customer requests, the gear is now made of high-grade brass as standard.

Materials

Rail: Corrosion-resistant steel X46 Cr13
Rollers: Bearing steel 100 Cr6
Cage: POM
Gear: Brass CuZn39Pb3

Guided precision now also available in size 2

In order to meet the increasing market demands for miniaturisation, the ACSM series was extended by size 2 rail guides.

Unlimited freedom

New manufacturing methods have enabled further improvements in the rail geometry to be achieved. The groove bottom in the raceway prism has been eliminated and the end face holes at the rail modules are no longer required. This results in higher system stiffness. Moreover, the gearing runs over the entire rail length continuously so that the “specified stroke” information, needed for the classic ACS, is rendered superfluous. In this way, customers are not restricted in their freedom when operating the precision rail guides.

Optimized geometry without groove bottom and end face hole



Continuous gearing

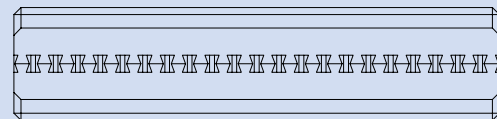

Unique solution for the accommodation of combined loads

As is the case with the ACS, the ACSM sizes 3, 6 and 9 are equipped with a segmented cage. This permits individual turning of the rolling elements by 90° along the longitudinal axis in order to adjust them to the load situation and load direction. In this way, the ACSM precision rail guides can be optimally adjusted to customer-specific requirements.

Individual adjustment of rolling elements

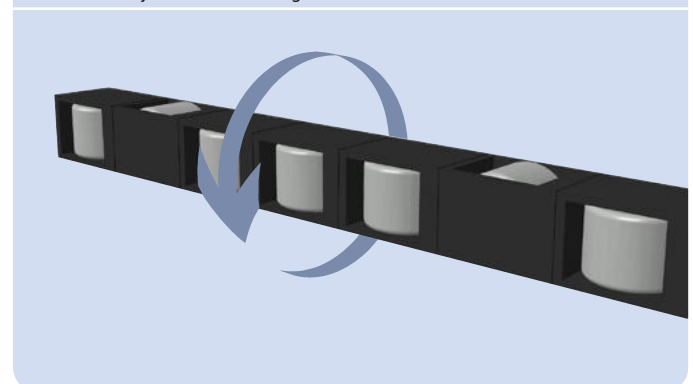

Advantages of the ACSM

High acceleration, vertical installation and collective loads with uneven preload or uneven load distribution are the primary causes for cage creep. The ACSM prevents the cage from wandering out of its correct position and thus increases the reliability and availability of machines and equipment.

The advantages at a glance:

- Significantly higher acceleration possible
- Vertical installation and uneven load distribution possible
- Higher accuracy through defined cage positioning
- Compatible with other SKF precision rail guides due to identical size and dimensions
- Low maintenance requirements and optimised availability of equipment

Tested quality

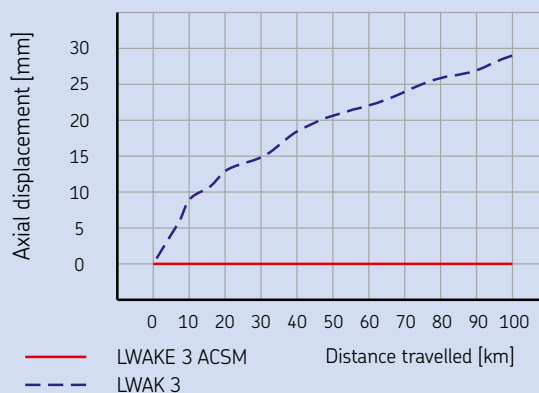

Test parameters

LWE 3150 compared to LWRE 3150 ACS
 Double strokes: 27 million
 Centric load: 1 000 N
 Acceleration: 16 g
 Speed: 3.2 m/s

Comparison of stiffness and stress

The improved gearing geometry thanks to modified manufacturing technology results in lower peak loads in the material. This leads to higher system stiffness

and absolute accuracy of the ACSM precision rail guides. Stress on the material is lower and the life expectancy is increased.

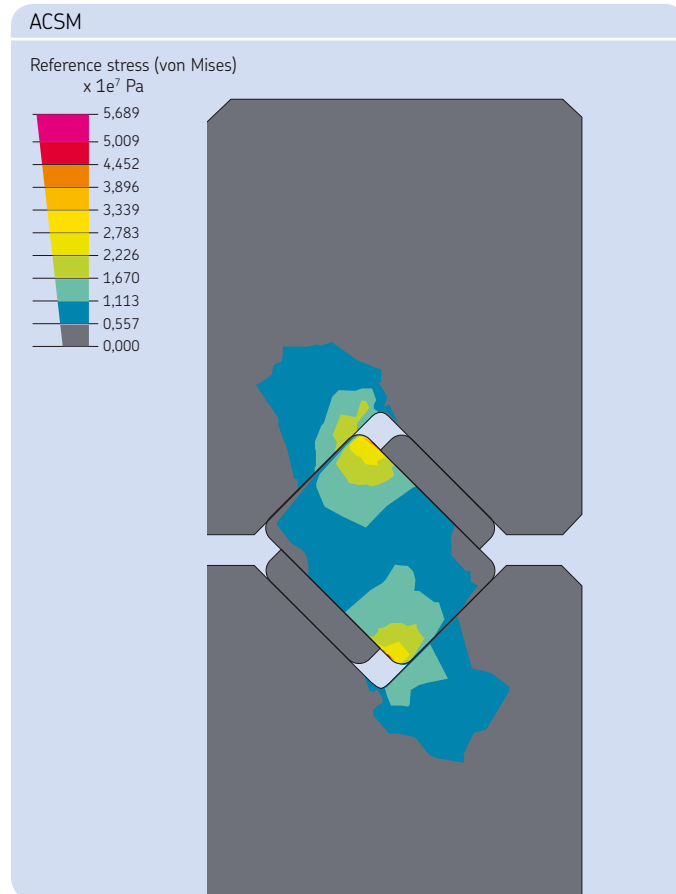
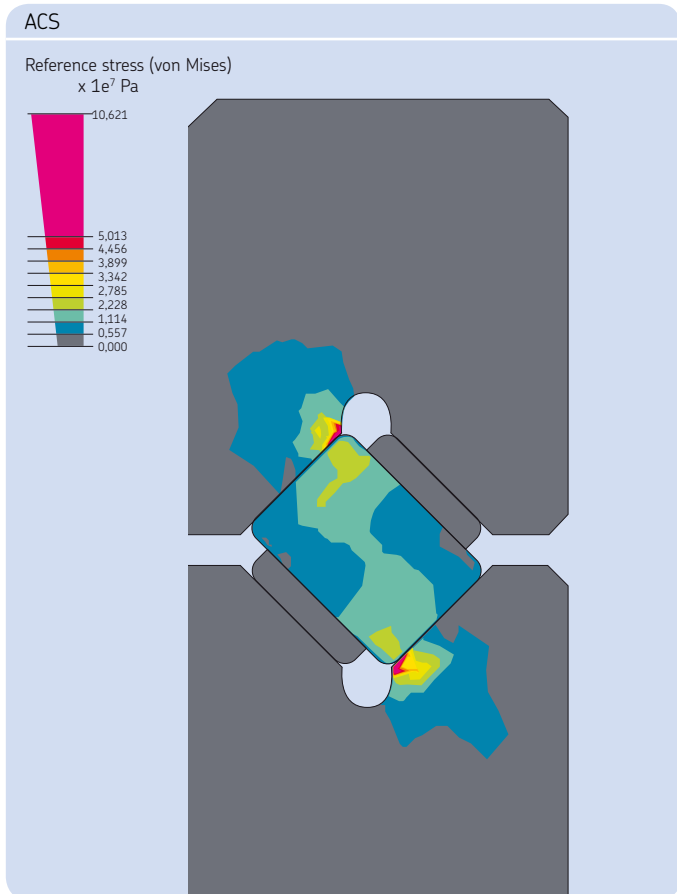

Precision rail guide

LWRE

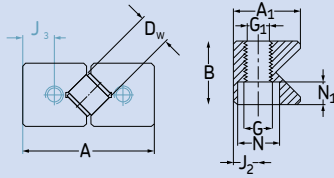

LWRB

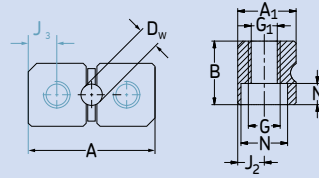

Standard or option E7 (with end face holes)

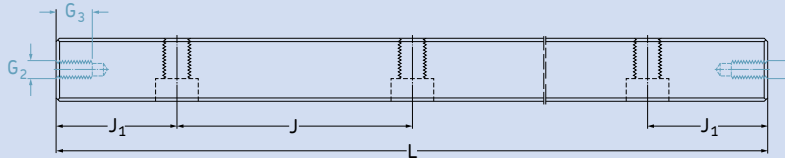

Designation	Dimensions		Attachment holes							End face holes				
	A	B	A ₁	D _w	J	J ₁	J ₂	G	G ₁	N	N ₁	J ₃	G ₂	G ₃
	mm							–	mm				–	mm
LWRB 2	12	6	5,5	2	15	7,5	2,5	M3	2,55	4,4	2	2,7	M2,5	3
LWRE 3	18	8	8,7	4	25	12,5	3,5	M4	3,3	6	3,2	4	M3	6
LWRE 6	31	15	15,2	8	50	25	6	M6	5,2	9,5	5,2	6,75	M5	9
LWRE 9	44	22	21,7	12	100	50	9	M8	6,8	10,5	6,2	9,75	M6	9

Cage dimensions and load ratings

Cage

LWJK 2 ACSM

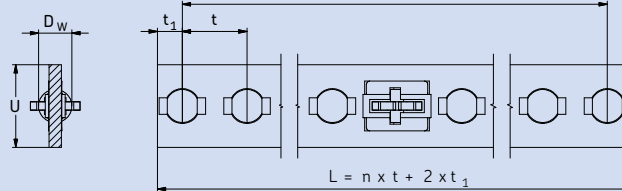

* One ball is replaced by the ACSM gear wheel

LWAKE 3, 6, 9 ACSM

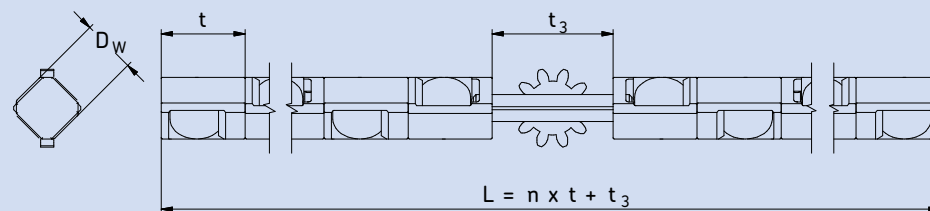

Designation	Dimensions			Load ratings for 10 rolling elements per row		Suitable rail guide
	D _w	t	t ₃	dynamic C	static C ₀	
	mm			N		–
LWJK 2 ACSM	2	3,9	3,9	510	650	LWRB 2 ACSM
LWAKE 3 ACSM	4	6,25	9	5 040	8 160	LWRE 3 ACSM
LWAKE 6 ACSM	8	11	15	27 200	37 440	LWRE 6 ACSM
LWAKE 9 ACSM	12	16	21,5	62 400	74 880	LWRE 9 ACSM

Available lengths¹⁾

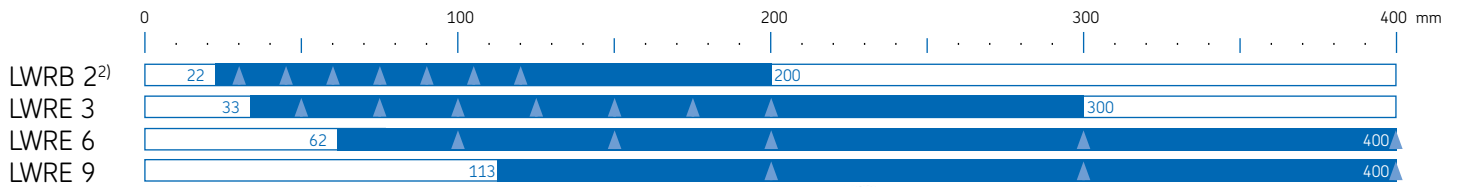

¹⁾ Standard lengths are indicated by light blue triangles

²⁾ Fitted with balls instead of rollers



ACSM precision rail guides in kit packaging

Designation	Load ratings ²⁾		Stroke mm	Rail type 4 pieces	Cage type ¹⁾ 2 pieces
	dynamic C	static C ₀			
	N			-	
LWRE 3050 ACSM KIT	2 940	4 080	19	LWRE 3050 ACSM	LWAKE 3 x 5 ACSM
LWRE 3075 ACSM KIT	3 380	4 900	57	LWRE 3075 ACSM	LWAKE 3 x 6 ACSM
LWRE 3100 ACSM KIT	5 040	8 160	57	LWRE 3100 ACSM	LWAKE 3 x 10 ACSM
LWRE 3125 ACSM KIT	6 180	10 610	69	LWRE 3125 ACSM	LWAKE 3 x 13 ACSM
LWRE 3150 ACSM KIT	7 270	13 060	82	LWRE 3150 ACSM	LWAKE 3 x 16 ACSM
LWRE 3175 ACSM KIT	7 970	14 690	107	LWRE 3175 ACSM	LWAKE 3 x 18 ACSM
LWRE 3200 ACSM KIT	9 320	17 950	107	LWRE 3200 ACSM	LWAKE 3 x 22 ACSM
LWRE 6100 ACSM KIT	18 260	22 460	38	LWRE 6100 ACSM	LWAKE 6 x 6 ACSM
LWRE 6150 ACSM KIT	25 050	33 700	72	LWRE 6150 ACSM	LWAKE 6 x 9 ACSM
LWRE 6200 ACSM KIT	31 360	44 930	106	LWRE 6200 ACSM	LWAKE 6 x 12 ACSM
LWRE 6250 ACSM KIT	39 240	59 900	118	LWRE 6250 ACSM	LWAKE 6 x 16 ACSM
LWRE 6300 ACSM KIT	44 870	71 140	152	LWRE 6300 ACSM	LWAKE 6 x 19 ACSM
LWRE 6350 ACSM KIT	52 090	86 110	164	LWRE 6350 ACSM	LWAKE 6 x 23 ACSM
LWRE 6400 ACSM KIT	57 310	97 340	198	LWRE 6400 ACSM	LWAKE 6 x 26 ACSM

¹⁾ Note: After cutting, the length of the cage (roller unit) should be at least 2/3 of the entire rail length

²⁾ Basis 55 HRC rounded

Prospective availability of the ACSM

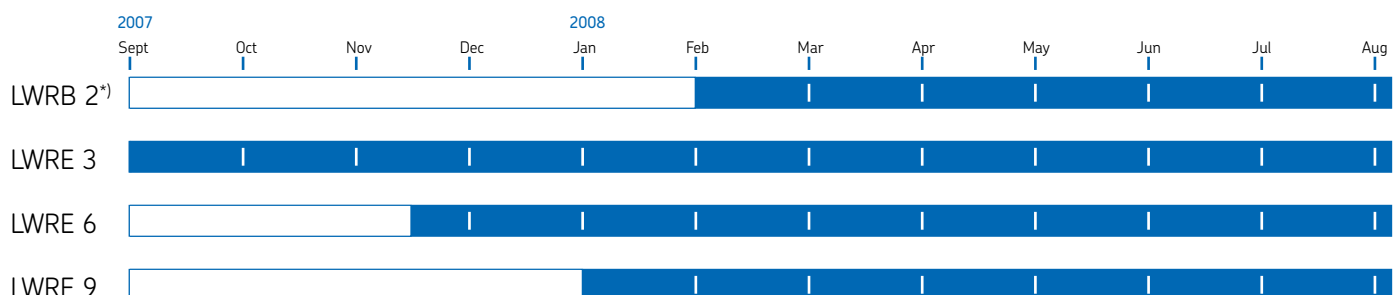

¹⁾ Fitted with balls instead of rollers

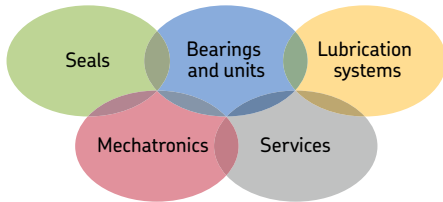

The Power of Knowledge Engineering

Drawing on five areas of competence and application-specific expertise amassed over more than 100 years, SKF brings innovative solutions to OEMs and production facilities in every major industry worldwide. These five competence areas include bearings and units, seals, lubrication systems, mechatronics (combining mechanics and electronics into intelligent systems), and a wide range of services, from 3-D computer modelling to advanced condition monitoring and reliability and asset management systems. A global presence provides SKF customers uniform quality standards and worldwide product availability.

This brochure was presented by:

© SKF is a registered trademark of the SKF Group.

© SKF Group 2010

The contents of this publication are the copyright of the publisher and may not be reproduced (even extracts) unless prior written permission is granted. Every care has been taken to ensure the accuracy of the information contained in this publication but no liability can be accepted for any loss or damage whether direct, indirect or consequential arising out of the use of the information contained herein.

PUB 6602/1 EN · Oktober 2010

